

4

3

2

1

D

D

C

C

B

B

A

A

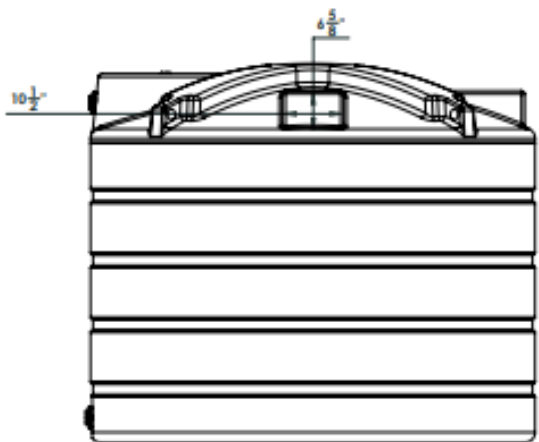
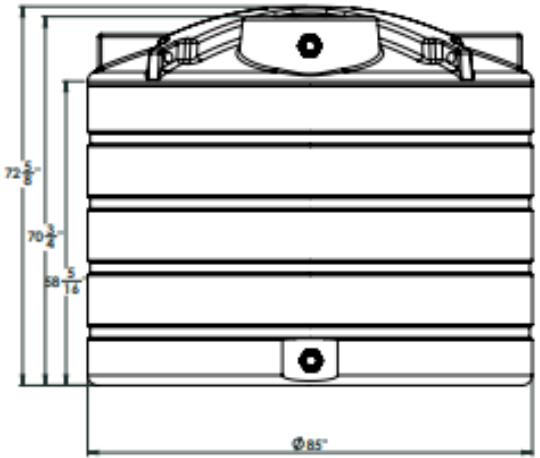
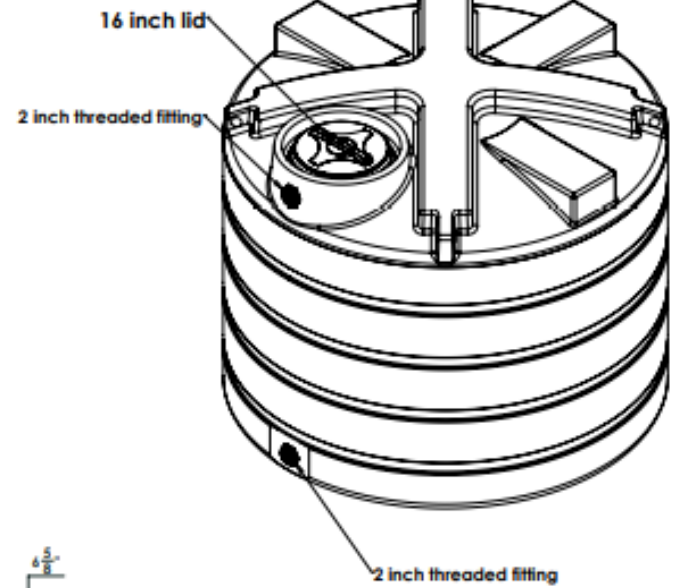

**NOTE: Allow +/- 1.5% Shrinkage**

<p><b>TECHNICAL AND GENERAL</b>          FOR INFORMATION CONTACT WITH          ENDURAPLAS AND ANY INFORMATION          CONTACT WITH ENDURAPLAS          ENDURAPLAS, INC. 10000 W. 10TH AVE. SUITE 100          DENVER, CO 80202-1000          TEL: 303.440.1000 FAX: 303.440.1001          WWW.ENDURAPLAS.COM</p>		<p><b>REVISIONS</b></p> <table border="1"> <tr> <th>NO.</th> <th>DATE</th> <th>DESCRIPTION</th> </tr> <tr> <td> </td> <td> </td> <td> </td> </tr> <tr> <td> </td> <td> </td> <td> </td> </tr> <tr> <td> </td> <td> </td> <td> </td> </tr> </table>	NO.	DATE	DESCRIPTION										<p><b>ENDURAPLAS LLC</b></p> <p><b>TLV01350</b></p> <p>SEE DWG. NO. <b>C</b> REV <b>1</b></p> <p>SCALE: 1:30(HIGH) SHEET 1 OF 1</p>
NO.	DATE	DESCRIPTION													